

CARATTERISTICHE - SPECIFICATIONS

IN	DIAMETER	∅	1" BSP
	PRESS.	Min.	-0.1 bar - 1.5 PSI
		Max.	6 bar 87 PSI
TEMP.	Max.	74° C. 165° F.	
OUT	DIAMETER	∅	1/2 BSP
SHAFT		∅	24 mm
OIL	SAE 75W90	1.4 litri	0.37 U.S.G.
PESO WEIGHT		Kg / lbs	16.1 / 35.4



INTELLiseal™



Dx R B T

OPTIONAL

F Sx G M

INTELLiseal H.W.™

KIT PIEDINI cod. 05.9890.97.3 (optional)
MOUNTING RAILS KIT cod. 05.9890.97.3 (optional)
KIT SUPPORTS cod. 05.9890.97.3 (option)
JUEGO DE PIES cod. 05.9890.97.3 (opción)

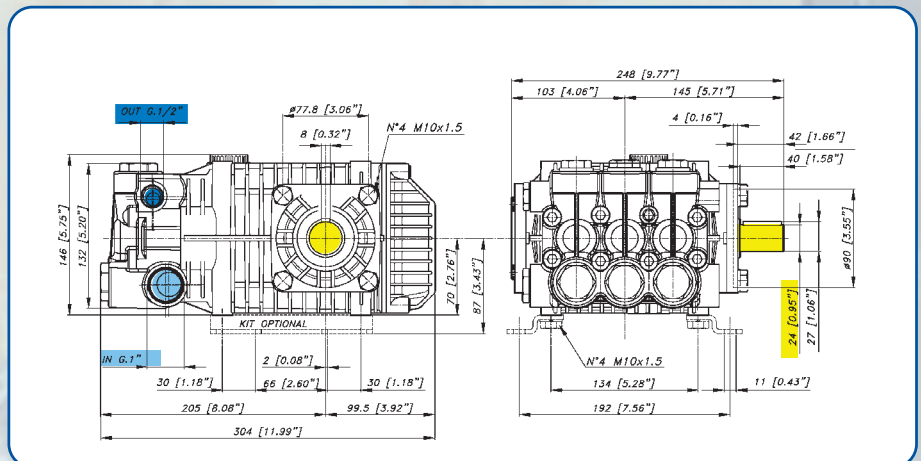

CARATTERISTICHE - FEATURES

PERFORMANCE CHART

MODELLO MODEL CODICE CODE	MAX		PRESS		RPM 950				RPM 1450				RPM 1725				PIST. CORSA PLUNG. STROKE	
	L/min	GPM	Bar	PSI	L/min	GPM	KW	HP	L/min	GPM	KW	HP	L/min	GPM	KW	HP	mm	mm
KKL 3021 06.4017.97.3	34,7	9,2	170	2465	19.5	5.2	6.5	8.7	29.5	7.8	9.8	13.2	34.7	9.2	11.6	15.5	22	19
			190	2755	19.4	5.1	7.2	9.7	29.3	7.7	10.9	14.7	34.5	9.1	12.9	17.3		
			210	3045	19.3	5.1	8.0	10.7	29.2	7.7	12.0	16.1	34.4	9.1	14.2	19.0		
KKL 3316 06.4018.97.3	38.7	10.2	120	1740	21.7	5.7	5.1	6.9	32.8	8.7	7.7	10.4	38.7	10.2	9.1	12.2	25	16.4
			140	2030	21.6	5.7	5.9	8.0	32.7	8.6	9.0	12.0	38.5	10.2	10.6	14.2		
			160	2320	21.5	5.7	6.8	9.1	32.5	8.6	10.2	13.7	38.3	10.1	12.0	16.1		
KKL 3816 06.4019.97.3	44.8	11.8	120	1740	25.2	6.7	5.9	8.0	38.1	10.1	9.0	12.0	44.8	11.8	10.6	14.2	25	19
			140	2030	25.1	6.6	6.9	9.2	37.9	10.0	10.4	14.0	44.6	11.8	12.3	16.4		
			160	2320	24.9	6.6	7.8	10.5	37.7	10.0	11.8	15.9	44.4	11.7	13.9	18.7		