

highest quality state of the art CUSTOMIZED PRECISION OF THE ART RBL

CARATTERISTICHE - SPECIFICATIONS

IN	DIAMETER	\varnothing	1" BSP
	PRESS.	Min.	-0.1 bar - 1.5 PSI
		Max.	6 bar 87 PSI
TEMP.	Max.	74° C. 165° F.	
OUT	DIAMETER	\varnothing	1/2 BSP
SHAFT		\varnothing	30 mm
OIL		SAE 75W90	1.5 litri 0.4 U.S.G.
PESO WEIGHT		Kg / lbs	19.5 / 43



INTELLIseal™



OPTIONAL



KIT PIEDINI cod. 08.9829.97.3 (optional)
 MOUNTING RAILS KIT cod. 08.9829.97.3 (optional)
 KIT SUPPORTS cod. 08.9829.97.3 (option)
 JUEGO DE PIES cod. 08.9829.97.3 (opción)

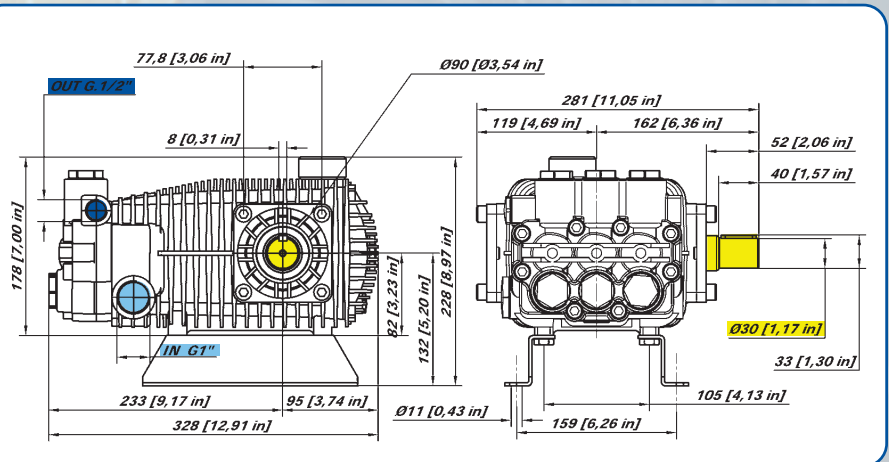

CARATTERISTICHE - FEATURES

PERFORMANCE CHART

MODELLO MODEL CODICE CODE	MAX		PRESS		RPM 950				RPM 1450				RPM 1725				PIST. CORSA PLUNG. STROKE	
	L/min	GPM	Bar	PSI	L/min	GPM	KW	HP	L/min	GPM	KW	HP	L/min	GPM	KW	HP	Dia. mm	mm
RBL 4219 08.1042.97.3	49.0	12.9	150	2175	27.5	7.3	8.1	10.9	41.6	11.0	12.3	16.4	49.0	12.9	14.4	19.4	25	21
			170	2465	27.4	7.2	9.1	12.3	41.4	10.9	13.8	18.5	48.8	12.9	16.3	21.8		
			190	2755	27.3	7.2	10.2	13.6	41.2	10.9	15.4	20.6	48.5	12.8	18.1	24.3		
RBL 5019 08.1004.97.3	50.0	13.2	150	2175	33.1	8.7	9.7	13.1	50.0	13.2	14.7	19.7	N.D. N.A.	25	25			
			170	2465	32.9	8.7	11.0	14.7	49.7	13.1	16.6	22.3						
			190	2755	32.7	8.6	12.2	16.4	49.5	13.1	18.5	24.8						