

## CARATTERISTICHE - SPECIFICATIONS

IN	DIAMETER	$\varnothing$	1/2 BSP
	PRESS.	Min.	- 0.1 bar - 1.5 PSI
		Max.	6 bar 87 PSI
TEMP.	Max.	74° C. 165° F.	
OUT	DIAMETER	$\varnothing$	3/8 BSP
SHAFT		$\varnothing$	24 mm
OIL	SAE 75W 90		0.7 litri 0.18 U.S.G.
PESO WEIGHT	Kg lbs		10 / 22



INTELLiseal™



OPTIONAL



INTELLiseal HW™

KIT PIEDINI cod. 07.9802.97.3 (optional)  
MOUNTING RAILS KIT cod. 07.9802.97.3 (optional)  
KIT SUPPORTS cod. 07.9802.97.3 (option)  
JUEGO DE PIES cod. 07.9802.97.3 (opción)

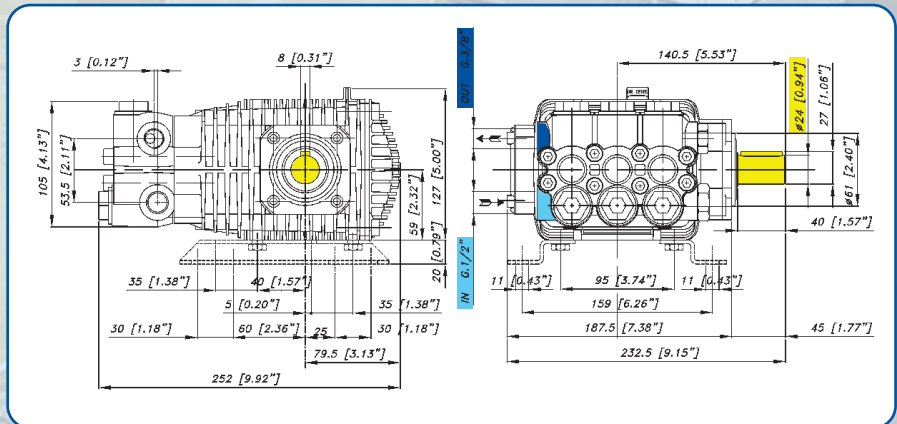

## CARATTERISTICHE - FEATURES

## PERFORMANCE CHART

MODELLO MODEL CODICE CODE	MAX		PRESS		RPM 950				RPM 1450				RPM 1725				PIST. PLUNG. Dia. mm	CORSA STROKE mm
	L/min	GPM	Bar	PSI	L/min	GPM	KW	HP	L/min	GPM	KW	HP	L/min	GPM	KW	HP		
TML 1328-HP 07.2071.97.3	15.0	4.0	210	3045	8.4	2.2	3.5	4.7	13.0	3.4	5.3	7.0	15.0	4.0	6.2	8.3	18	12.4
			250	3625	8.4	2.2	4.1	5.5	12.9	3.3	6.2	8.3	14.9	3.9	7.3	9.8		
			280	4060	8.3	2.2	4.6	6.2	12.8	3.3	6.9	9.3	14.9	3.9	8.2	11.0		
TML 1528-HP 07.2072.97.3	17.4	4.6	210	3045	9.8	2.6	4.0	5.4	15.0	4.0	6.1	8.2	17.4	4.6	7.2	9.6	18	14.4
			250	3625	9.7	2.6	4.8	6.4	14.9	3.9	7.2	9.7	17.3	4.6	8.5	11.4		
			280	4060	9.7	2.6	5.3	7.1	14.8	3.9	8.1	10.8	17.2	4.6	9.5	12.7		
TML 1728-HP 07.2073.97.3	19.4	5.1	210	3045	10.9	2.9	4.5	6.0	17.0	4.5	6.8	9.1	19.4	5.1	8.0	10.7	18	16
			250	3625	10.8	2.9	5.3	7.1	16.9	4.4	8.0	10.8	19.3	5.1	9.5	12.7		
			280	4060	10.8	2.8	5.9	7.9	16.8	4.4	8.9	12.0	19.2	5.1	10.5	14.1		
TML 2028-HP 07.2074.97.3	22.6	6.0	210	3045	12.7	3.4	5.2	7.0	20.0	5.2	7.9	10.6	22.6	6.0	9.3	12.5	18	18.7
			250	3625	12.6	3.3	6.2	8.3	19.9	5.2	9.4	12.6	22.5	5.9	11.1	14.8		
			280	4060	12.6	3.3	6.9	9.3	19.8	5.1	10.5	14.0	22.4	5.9	12.3	16.5		