

# highest quality state of the art CUSTOMER QUALITY PRECISION

# WBL-F

## CARATTERISTICHE - SPECIFICATIONS

IN	DIAMETER	$\varnothing$	3/8 BSP
	PRESS.	Min.	1 bar 15 PSI
		Max.	6 bar 87 PSI
TEMP.	Max.	60° C. 140° F.	
OUT	DIAMETER	$\varnothing$	3/8 BSP
SHAFT		$\varnothing$	24 mm
OIL		SAE 75W 90	0.5 litri 0.13 U.S.G.
PESO WEIGHT		Kg / lbs	5.8 / 12.8



OPTIONAL



PIEDINI cod. 02.9829.97.3 (optional)  
MOUNTING RAILS KIT cod. 02.9829.97.3 (optional)  
KIT SUPPORTS cod. 02.9829.97.3 (option)  
JUEGO DE PIES cod. 02.9829.97.3 (opción)

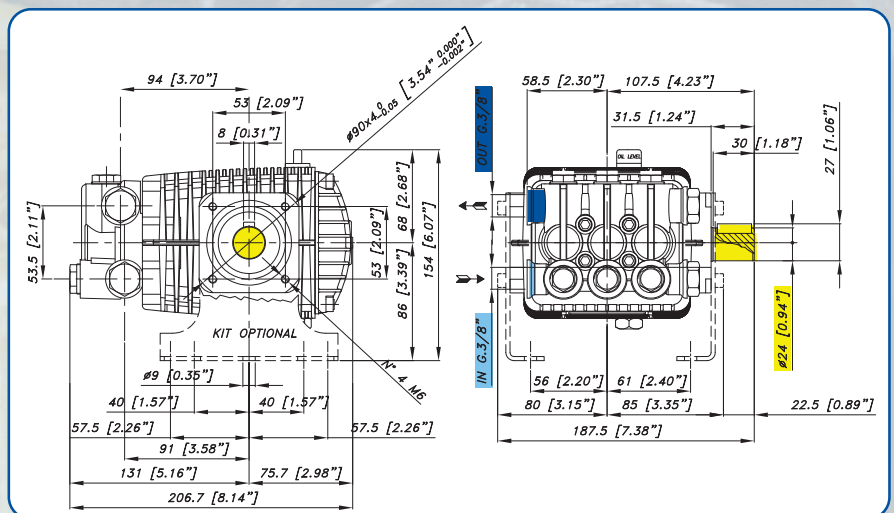

## CARATTERISTICHE - FEATURES

### WBL-F 2800 rpm

## PERFORMANCE CHART

CODICE CODE	MODELLO MODEL	PRESS MAX / MAX PRESSURE		PORTATA / FLOW		POTENZA / POWER		PIST. PLUNG. Dia. mm	CORSA STROKE mm
		Bar	PSI	L/min	GPM	KW	HP		
02.6020.97.3	WBL 809-F	90	1300	8	2.1	1.4	1.9	15	6
02.6021.97.3	WBL 812-F	120	1750	8	2.1	1.9	2.5		
02.6022.97.3	WBL 814-F	140	2000	8	2.1	2.2	2.9		
02.6023.97.3	WBL 1010-F	100	1450	10	2.6	1.8	2.5	15	7
02.6024.97.3	WBL 1012-F	120	1750	10	2.6	2.2	2.9		
02.6025.97.3	WBL 1016-F	160	2300	10	2.6	2.9	3.9		
02.6026.97.3	WBL 1110-F	100	1450	11	2.9	2.1	2.8	15	8
02.6027.97.3	WBL 1114-F	140	2000	11	2.9	2.9	3.9		
02.6028.97.3	WBL 1309-F	90	1300	13	3.4	2.2	2.9	15	9.2
02.6029.97.3	WBL 1312-F	120	1750	13	3.4	2.8	3.8		
02.6032.97.3	WBL 1410-F	110	1600	14	3.7	2.9	3.9	15	10